



**equipment & turn-key lines
for hot melt adhesive application**

add value to your production



narrow web converter

turn-key solutions

Narrow Web Converter : for any production needs



Mechanical performances : basic and optionals

Web width (mm)	100-1400
Speed (m/min)	any
Tension control	any
Nip	available
Chill rolls	available
Web's flow supervision	available

Web : size

Diameter (mm)	up to 1500
Core (inch)	3 or 6

HIP-MITSU melter usable

Tank melter	any
Drum melter	any

End User interface

System's Supervision	available
Remote Control	available
Teleassistance	available
Factory EDP integration	available

Coating performances : basic and optionals

Coating width (mm)	0,3 - 1400
Coating width set up (sec)	1
Coating weigth (gsm)	0,3-1500
Coating weigth set up (sec)	1
Sigma coating weigth in CD	1%
Sigma coating weigth in MD	1%
Intermittence (Hertz)	45
Pattern available	all
Pattern's change (min)	5
Adhesive's change (min)	10
Automatic cleaning system	available

Coating weight : set and controls

Automatic	available
Independent from the variation of the main process parameters	available

Open Platform

increasing of the machine's performances in the future	yes
--	-----

Narrow Web Converter : customised solutions

Thanks to a modular design, HIP-MITSU produces well-tested, reliable and customised solutions which can meet all specific production needs.

Here below, for example, you can find some configurations realised by HIP-MITSU engineering.

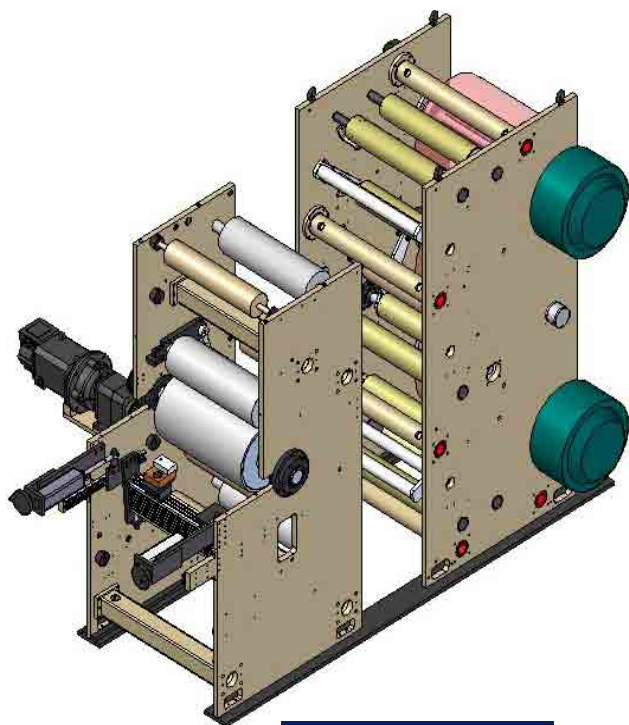

3d view

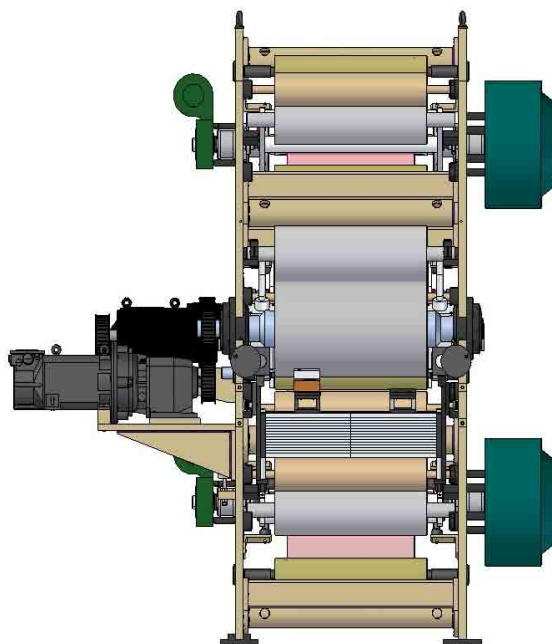

Front view

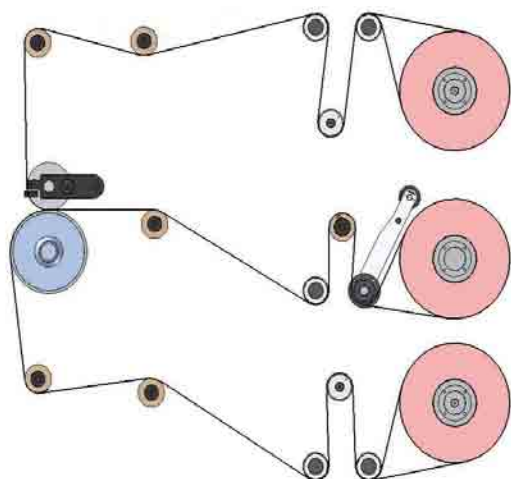

Tread up : example

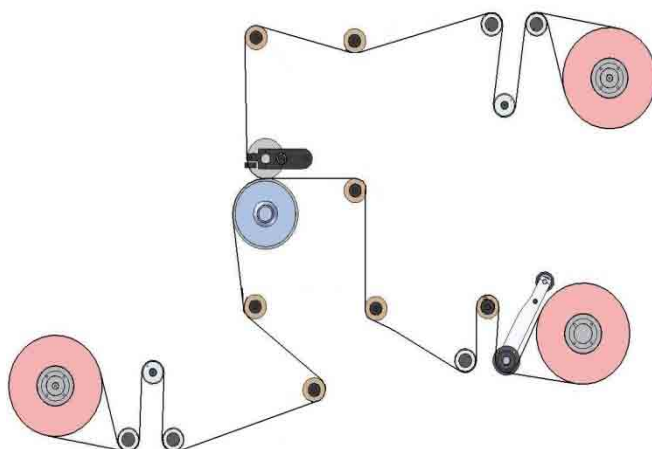

Tread up : example

GENERAL SERVICES

Competence Center – Production Lines for tests execution

HIP-MITSU Competence Center, equipped with the most advanced technologies and production lines, helps Customers during the application development enabling adhesive, polymers and materials testing.

Free Demo in real production's conditions are available every day on HIP-MITSU equipment, lines and systems.

A full assistance to customers during each phase of the project

- *Polymer/adhesive's research*
- *Sampling*
- *Project engineering*

Training Courses for end users

HIP-MITSU offers to its Customers complete training courses including both theoretical and practical sections.

Full papers - available in five languages - are supplied at each course to all participants.

Courses available for : line operator; mechanical maintenance staff; electrical maintenance staff.

Periodical Maintenance Service

Complete programs of periodical maintenance, which can take place both at HIP-MITSU and customer's site.

Spare Parts

HIP-MITSU spare parts service avails itself of the main international couriers ensuring spare parts delivery the day after the order receipt

A worldwide sales network

HIP-MITSU is worldwide locally present with a network of highly skilled professionals, who ensure a quick and qualified answer

First Installation and Technical Assistance

HIP-MITSU technical assistance service is hold by a team of skilled English-speaking technicians operating worldwide for many years, who ensures a highly professional support both during the installation and the technical assistance.

HIP-MITSU working team includes : *process engineers; mechanical maintenance staff; electrical maintenance staff; electronic maintenance staff; PLC software technicians; PC software technicians.*

HIP-MITSU: a "Cappuccino" Idea

HIP-MITSU technology is really a "cappuccino" idea : as milk adds value to a coffee cup, so it adds value to the roll goods produced by the end user.



add value to your production

HEAD OFFICE

I - 31027 SPRESIANO (TV) Italy - Via A. Volta, 1
Tel. + 39 0422 887.566 r.a. - Fax + 39 0422 887.337 - <http://www.hip-mitsu.com> e-mail: info@hip-mitsu.com